

BiSON

Birmingham
Solar-Oscillations
Network

TECHNICAL REPORT NO. 316

The Sutherland Temperature Controllers

Ian Barnes

The University of Birmingham, Edgbaston, Birmingham B15 2TT

2009 January 29

This technical report series is published by:



**THE UNIVERSITY
OF BIRMINGHAM**

High-Resolution Optical-Spectroscopy Group

School of Physics and Astronomy
The University of Birmingham
Edgbaston, Birmingham B15 2TT, United Kingdom
Telephone: +44-121-414-4551 FAX: +44-121-414-1438

The Sutherland Temperature Controllers

Ian Barnes

The University of Birmingham, Edgbaston, Birmingham B15 2TT

2009 January 29

Abstract

Some technical information on the configuration of the Sutherland Temperature Controllers is presented.

Contents

1	Introduction	1
2	Unit Design	2
3	PCB Configuration	6
4	Internal Wiring	9
5	System Design	17
6	External Connections & Cable Assemblies	19
7	Mechanical Drawings	24

1 Introduction

The Sutherland Temperature Controllers [1] were installed in 2007 August [2]. Originally this unit had four separate channels but since the decision was taken to temperature control the oven bottom then one of the later five channel units was needed.

Therefore the unit that was originally installed in Sutherland has been replaced with a new five channel unit and this report details the exact configuration of the unit.

2 Unit Design

Like many other HiROS units the Temperature controller has been designed to be a self-contained unit. The Temperature controller is housed in a 2U case and contains its own power supplies.

As so many other HiROS units all of the connections to the Temperature Controller feed to the rear panel of the unit with all of the controls and indicators being present on the front panel.

2.1 The Front Panel

The front panel of the Temperature Controller contains the main power switch, and various LEDs that indicate the status of the unit to the user. Figure 1 shows the Temperature Controller front panel.



Figure 1: The Temperature Controller Front Panel.

Directly underneath the power switch are three LEDs that show that the “analogue” or “clean” power rails are active. Next to these LEDs are another set of three LEDs that show that the “digital” or “dirty” rails are operational.

On the far right of the front panel there is a group of four LEDs that show the status of the RS-232 lines. The left hand pair indicate the status of the TX line and the RX line is the remaining two LEDs.

2.2 The Rear Panel

The rear panel of the Temperature Controller is shown in Figure 2.

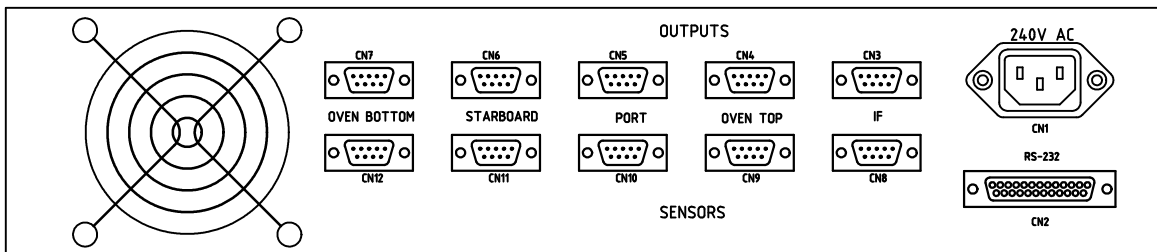

Figure 2: The Temperature Controller Rear Panel

At the far right of the rear panel is the inlet for the mains power. Underneath the ac inlet is the 25-pin D-type connector that connects to the serial port of the computer.

Next to this are two banks of five 9-pin D-Type connectors. The bottom row of connectors is all the temperature sensor feeds from the various spectrometer components that are to be

temperature controlled by the units. The five connectors on the top row are the high-current feeds to the heater/cooling elements for each spectrometer component.

On the far left of the rear panel is the case fan which is needed to dissipate the excess heat that is generated within the Temperature Controller unit itself.

2.3 Internal Layout

Figure 3 shows how the main components are arranged to fit inside the case.

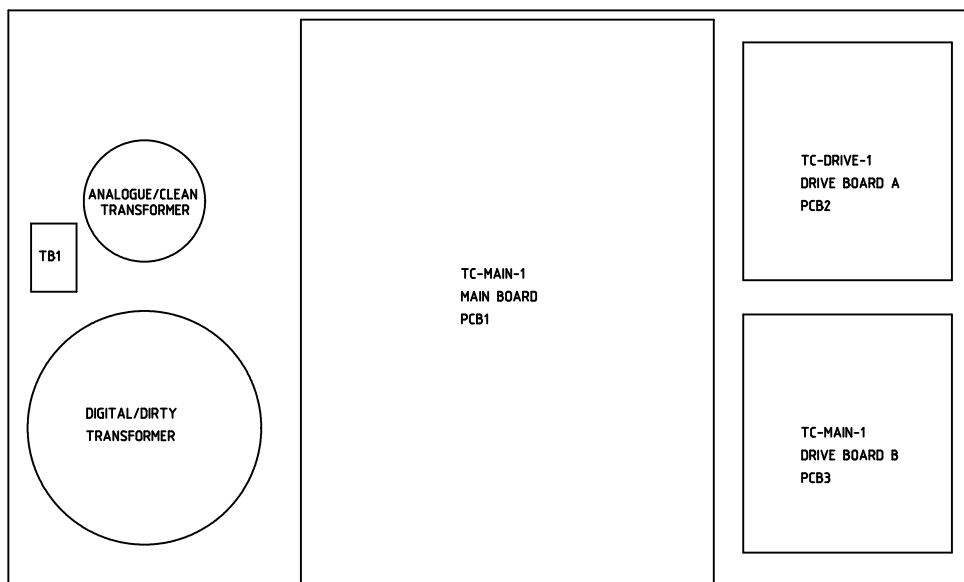

Figure 3: The Internal Layout of the Temperature Controller Unit.

2.4 Parts List

The parts list for the Sutherland Temperature Controller is too large to fit in a single table. Hence it has been split into several smaller tables according to component type. These tables are summarized in Table 1. A spare parts kit is also supplied.

Table 1: Sutherland Temperature Controller — Case Parts Lists

<i>Component Type</i>	<i>Table</i>	<i>Page</i>
Case	2	4
PCB Sub Assemblies	3	5
Spare Parts Kit	4	5

Table 2: Parts List — Case

Name	Part Number	Description (SSM)
—	RS 584-227	Rack Case 2U × 84 HP × 254 mm
SW1	Rapid 75-0335	DPST Green Visirocker Switch
CN1	Rapid 26-1250	IEC Inlet Filter 6A
CN2	Rapid* 15-0535	25-pin Female D-Type Connector
CN3– CN7	Rapid* 15-0150	9-pin Female D-Type Connector
CN8– CN12	Rapid* 15-0100	9-pin Male D-Type Connector
TR1	Rapid 88-3403	Toroidal Transformer +15V 0.176A
TR2	Rapid 88-2638	Toroidal Transformer +15V 7.5A
TB1	FEC 117-0378	Terminal Block 2-Way Connector
FAN1	Rapid 37-0907	80mm 12-V Box Fan
—	Rapid 37-0825	80mm Fan Finger Guard
—	RS 211-0907	IEC Inlet Insulating Boot (5)
—	FEC 769-277	Heatshrink Boot 28mm
—	Rapid* 15-0365	D-type 8mm Female Screwlock Kit
—	Rapid* 33-3525	M3 × 12 Hexagonal Spacers pk25
—	Rapid* 33-4210	M3 × 6 Panhead Pozidriv Screw pk100
—	Rapid* 33-4260	M3 × 6 Pozidriv Countersunk Screw pk100
—	Rapid* 33-4200	M2.5 × 6 Pozidriv Panhead Screw pk100
—	Rapid* 33-1715	M4 Nuts pk100
—	Rapid* 33-1765	M4 Washer pk100
—	Rapid* 33-2975	M4 × 20 Pozidriv Panhead Screw pk100
—	Rapid* 33-2977	M4 × 25 Pozidriv Panhead Screw pk100

*These items are available from Physics Stores.

Table 3: Parts List — PCB Sub Assemblies

Name	Part Number	Description (SSM)
PCB1	HiROS TC-MAIN-3	Main Board PCB Assembly
PCB2	HiROS TC-DRIVE-3	Drive Board PCB Assembly
PCB3	HiROS TC-DRIVE-5	Drive Board B PCB Assembly
PCB4– PCB5	HiROS PWR-LED-4	Power-LED Board PCB Assembly
PCB6	HiROS 232-LED-3	RS232-LED Board PCB Assembly

Table 4: Parts List — Spare Parts Kit

Part Number	Description (SSM)
Rapid 73-3206	PIC16F877-20P Microcontroller
FEC 789-872	ADS1210 24-bit ADC
RS 225-4883	MAX536ACPE Quad 12-bit DAC
FEC 130-5157	INA114 Instrumentation Amplifier
Rapid 82-0148	MAX232CPE RS-232 Line Driver IC
Rapid 82-0066	TL084 Quad Op-amp IC
Rapid 47-0156	ZVN2106A n-channel MOSFET
Rapid 47-0174	ZVP2106A p-channel MOSFET
Rapid 47-3278	78L05 +5-V 100-mA Voltage Regulator
Rapid 47-3282	78L15 +15-V 100-mA Voltage Regulator
Rapid 47-3284	79L05 -5-V 100-mA Voltage Regulator
Rapid 47-3288	79L15 -15-V 100-mA Voltage Regulator
Rapid 82-1002	LM35DZ Temperature Sensor IC
RS 284-220	TLE2426CLP Voltage Reference
Rapid 26-0840	0.17-A Resettable Fuse
Rapid 26-0825	8-A Resettable Fuse

3 PCB Configuration

The Temperature Controller [3] is a generic device that can be configured in many different ways depending on the actual components that are present.

The Fred spectrometer as fitted in Sutherland has the following components that require temperature control:

- Port Detector.
- Starboard Detector.
- Oven Top.
- Interference Filter.
- Oven Bottom.

3.1 Output Channel Allocation

The Sutherland Temperature Controller requires two of the drive boards to enable it to control the temperatures of components within Fred and the ancillary outputs that are needed by the temperature controller itself.

Table 5 shows how the components have been allocated to the available output channels on the Sutherland Temperature Controller.

Table 5: Channel Allocation of the Sutherland Temperature Controller

<i>Component</i>	<i>Drive Board</i>	<i>Output Channel</i>
Port Detector	A	A
Case Fan	A	B
Oven Top	A	C
Heatsink Fan	A	D
Interference Filter (IF)	B	A
Oven Bottom	B	B
Starboard Detector	B	C
Heatsink Fan	B	D

3.2 Output Configuration

Figure 4 shows a generic version of the output stage of the temperature controller. The drawing contains a number of components that are changed to enable the unit to control different types of component.

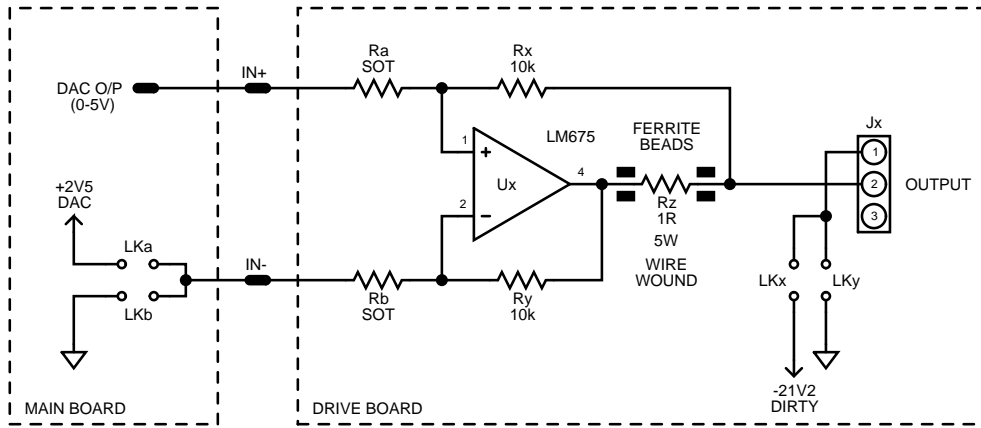

Figure 4: Temperature Controller Output Stage.

There are components on both the main board and on the drive board that are changed depending on the component that they are driving. LKa and LKb on the main board set the reference voltage which determines unipolar or bipolar current range.

The majority of components that can be configured are on the Drive board. Ra and Rb are the gain resistors and they set the overall gain of the amplifier. Then there is the output links LKx and LKz. LKy is used in bipolar mode while LKx is used in unipolar mode.

Table 6 shows the values of the components as used on the Sutherland Temperature Controller. The gain resistors column shows the names used on the drive board for the components on the output in question. For the output link this shows which link to populate with a zero-ohm link on the drive board. The reference link shows which link to populate on the main board.

Table 6: Configuration of the Drive boards

<i>Component</i>	<i>Drive Board</i>	<i>Output Channel</i>	<i>Gain Resistors</i>		<i>Value</i>	<i>Output Link</i>	<i>Reference Link</i>
Port	A	A	R4	R5	47-k Ω	LK5	LK14
Case Fan	A	B	R6	R7	270-k Ω	LK2	LK3
Oven Top	A	C	R8	R9	24-k Ω	LK7	LK4
Heatsink Fan	A	D	R10	R11	470-k Ω	LK8	LK5
IF	B	A	R4	R5	24-k Ω	LK5	LK6
Oven Bottom	B	B	R6	R7	24-k Ω	LK2	LK7
Starboard	B	C	R8	R9	47-k Ω	LK3	LK20
Heatsink Fan	B	D	R10	R11	470-k Ω	LK8	LK9

3.3 PCB Configuration Parts

The parts to complete the PCB configuration of the Temperature Controller have been split up into separate tables. These tables are summarized in Table 7.

Table 7: PCB Configuration Parts Lists

<i>Drawing</i>	<i>Figure</i>	<i>Page</i>
Drive Board A SOT Components	8	8
Drive Board B SOT Components	9	8
Main Board SOT Components	10	8

Table 8: PCB Configuration Parts List — Drive Board A SOT Components

Name	Part Number	Description (SSM)
R4–R5	Rapid* 62-0942	47-k Ω 0.25W 1% MR25 Resistor pk100
R6–R7	Rapid* 62-0942	270-k Ω 0.25W 1% MR25 Resistor pk100
R8–R9	Rapid* 62-0924	24-k Ω 0.25W 1% MR25 Resistor pk100
LK2 [†] , LK5, LK7, LK8	FEC 933-9027	0- Ω Link MCF Series (50)

*These items are available from Physics Stores.

[†]Any links in the range of LK1—LK8 not in this list are depopulated.

Table 9: PCB Configuration Parts List — Drive Board B SOT Components

Name	Part Number	Description (SSM)
R4–R7	Rapid* 62-0924	24-k Ω 0.25W 1% MR25 Resistor pk100
R8–R9	Rapid* 62-0942	270-k Ω 0.25W 1% MR25 Resistor pk100
LK2 [†] – LK3, LK5, LK8	FEC 933-9027	0- Ω Link MCF Series (50)

*These items are available from Physics Stores.

[†]Any links in the range of LK1—LK8 not in this list are depopulated.

Table 10: PCB Configuration Parts List — Main Board SOT Components

Name	Part Number	Description (SSM)
LK2 [†] – LK3, LK6– LK7, LK9, LK14, LK20	FEC 933-9027	0- Ω Link MCF Series (50)

[†]Any links in the ranges of LK2—LK9 and LK14—LK21 that are not in this list are depopulated.

4 Internal Wiring

The Temperature Controller system is made up of several different PCBs and the layout within the case has already been shown in Figure 3.

Most of the electronics for the Temperature controller are contained on the Main board. The unit does require eight high-current outputs and these are provided by the two drive boards, each board having four such outputs.

Because the system contains different PCBs it means that there is a lot of interconnections that need to be made internally on the system wiring.

4.1 Internal Wiring Diagram

Table 11 summarizes the individual drawings that make up the internal wiring diagram for the Narrabri Temperature Controller.

Table 11: Internal Wiring Diagram — Common Connections

<i>Drawing</i>	<i>Figure</i>	<i>Page</i>
AC Power Supplies	5	10
DC Power Distribution	6	11
RS-232 Communications Interface	7	12
Spectrometer Components — Drive Board A	8	13
Spectrometer Components — Drive Board B	9	14

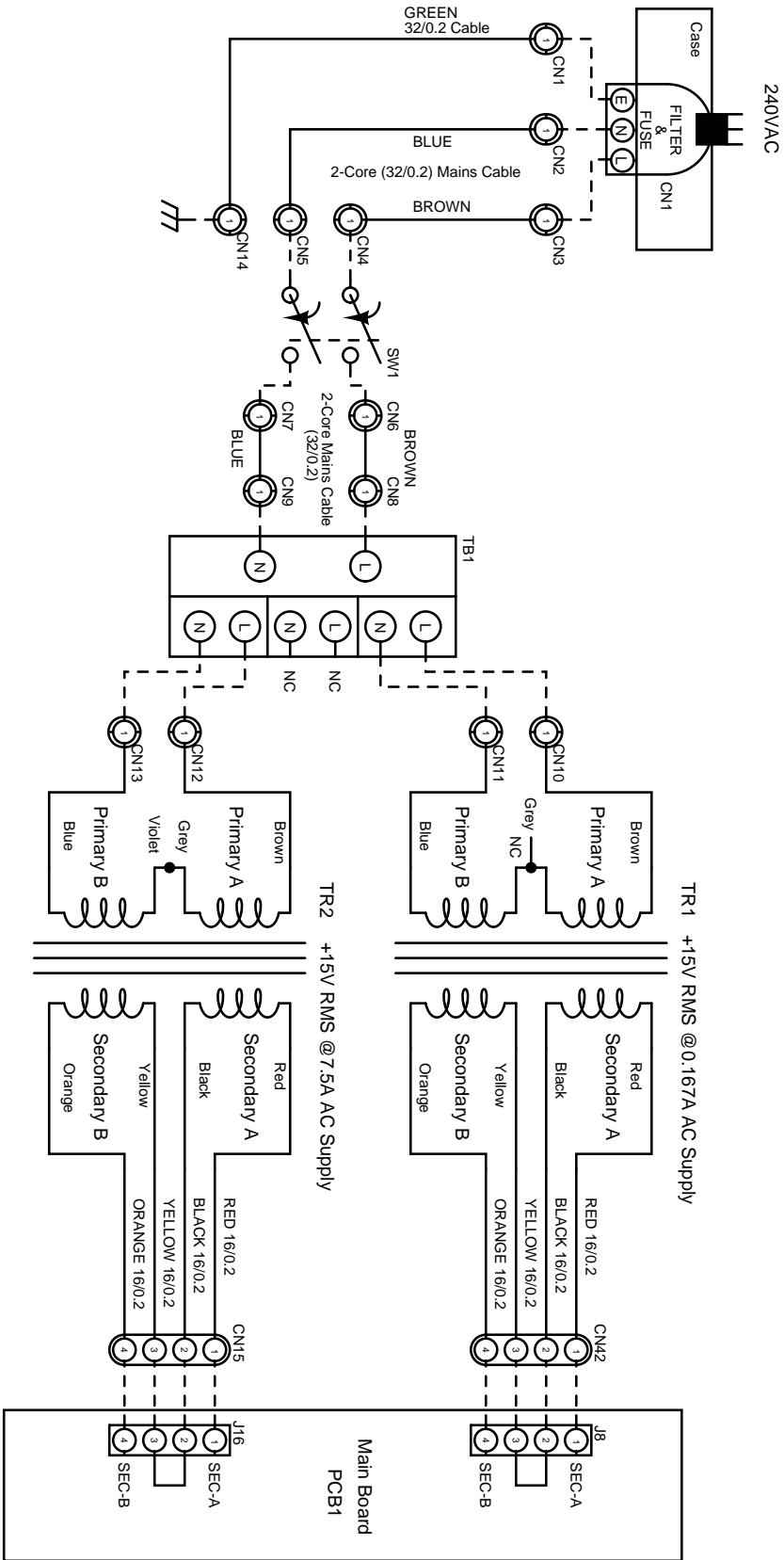

Figure 5: The Wiring Diagram for the AC Power Supplies.

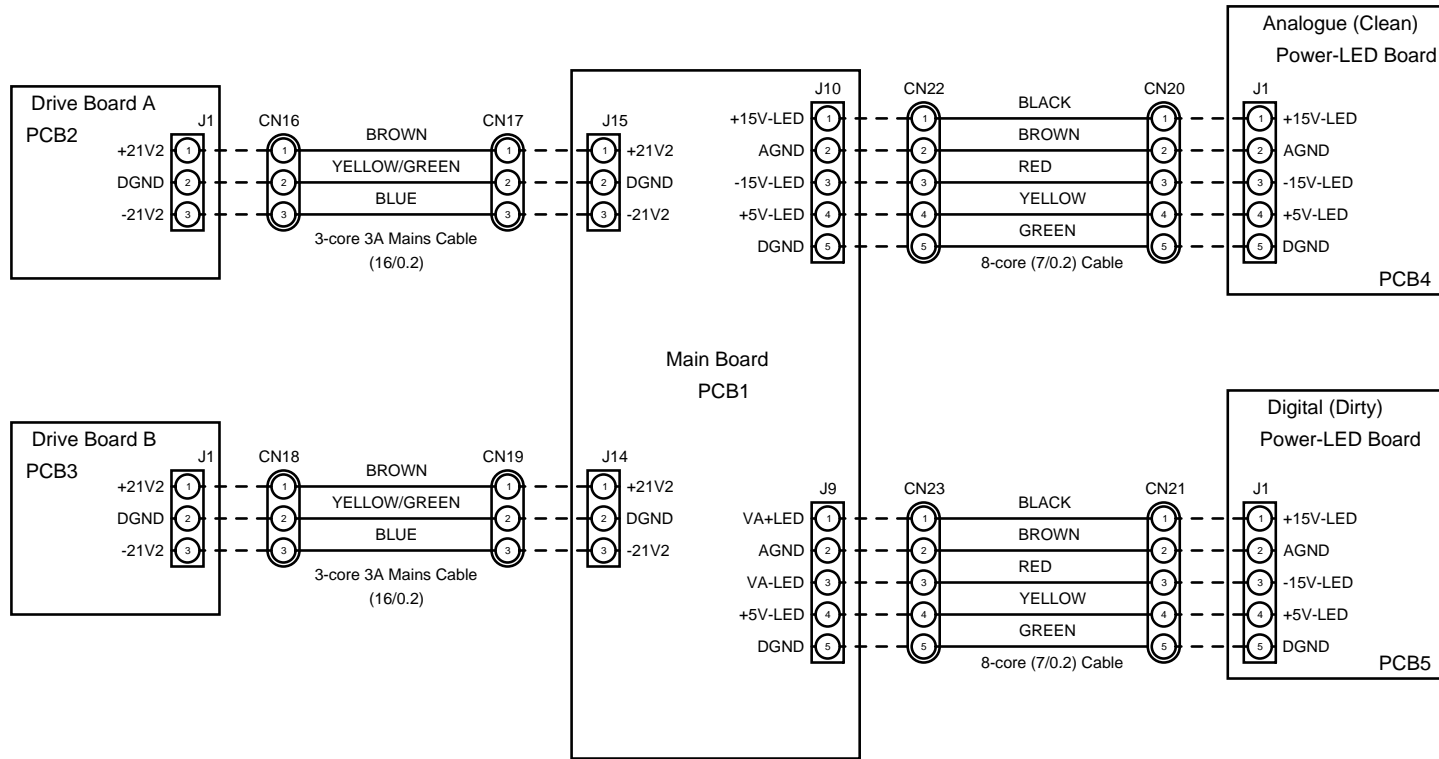

Figure 6: The DC Power Distribution.

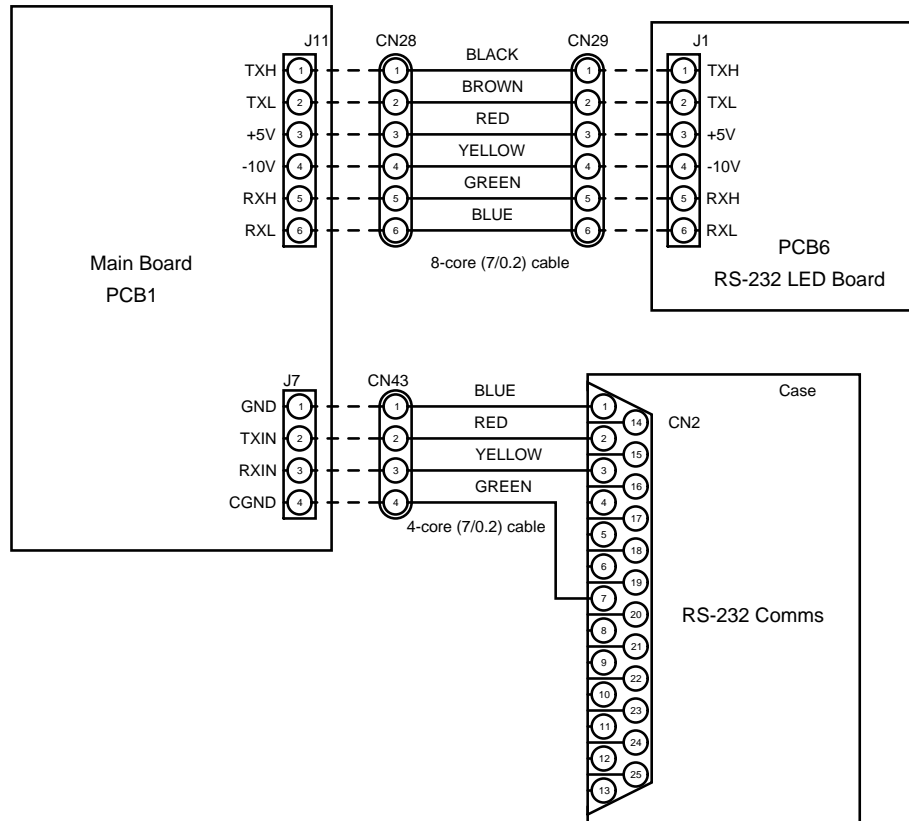

Figure 7: RS-232 Communications Interface.

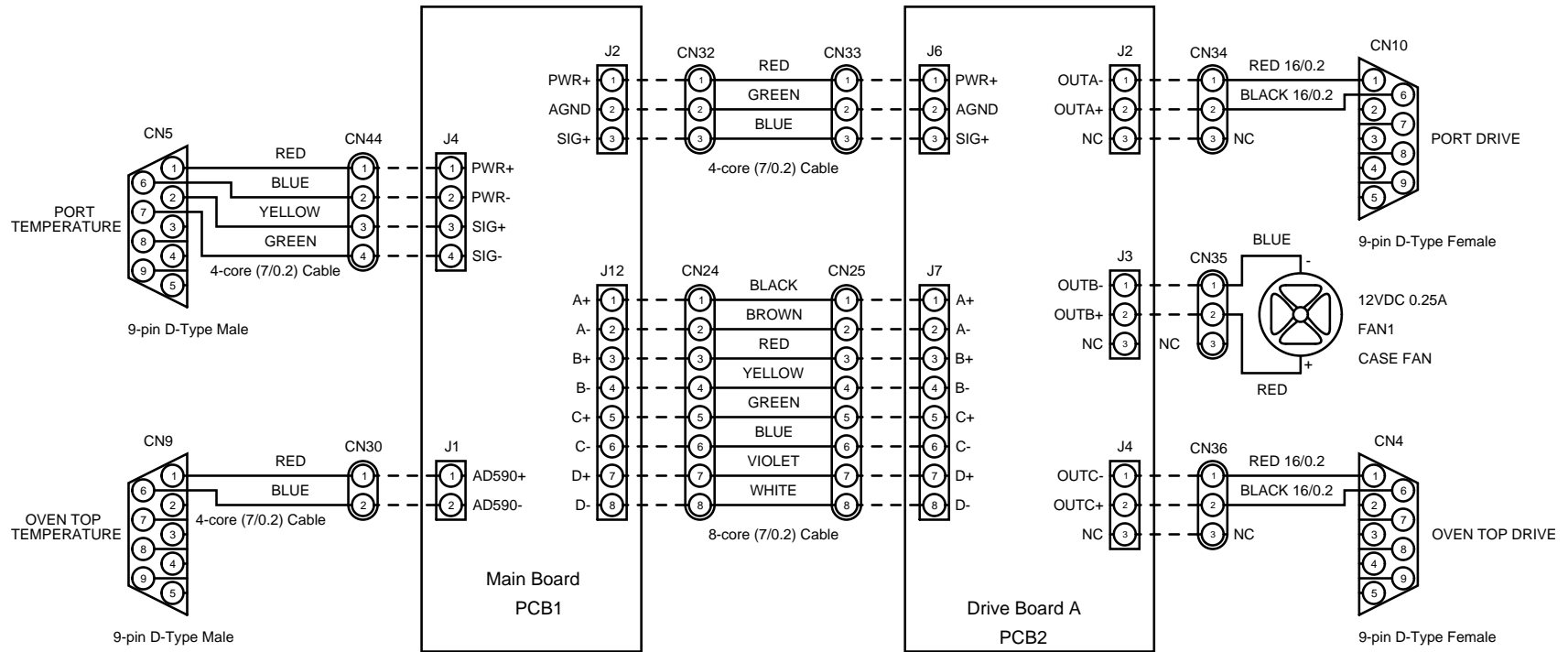

Figure 8: Spectrometer Components — Drive Board A.

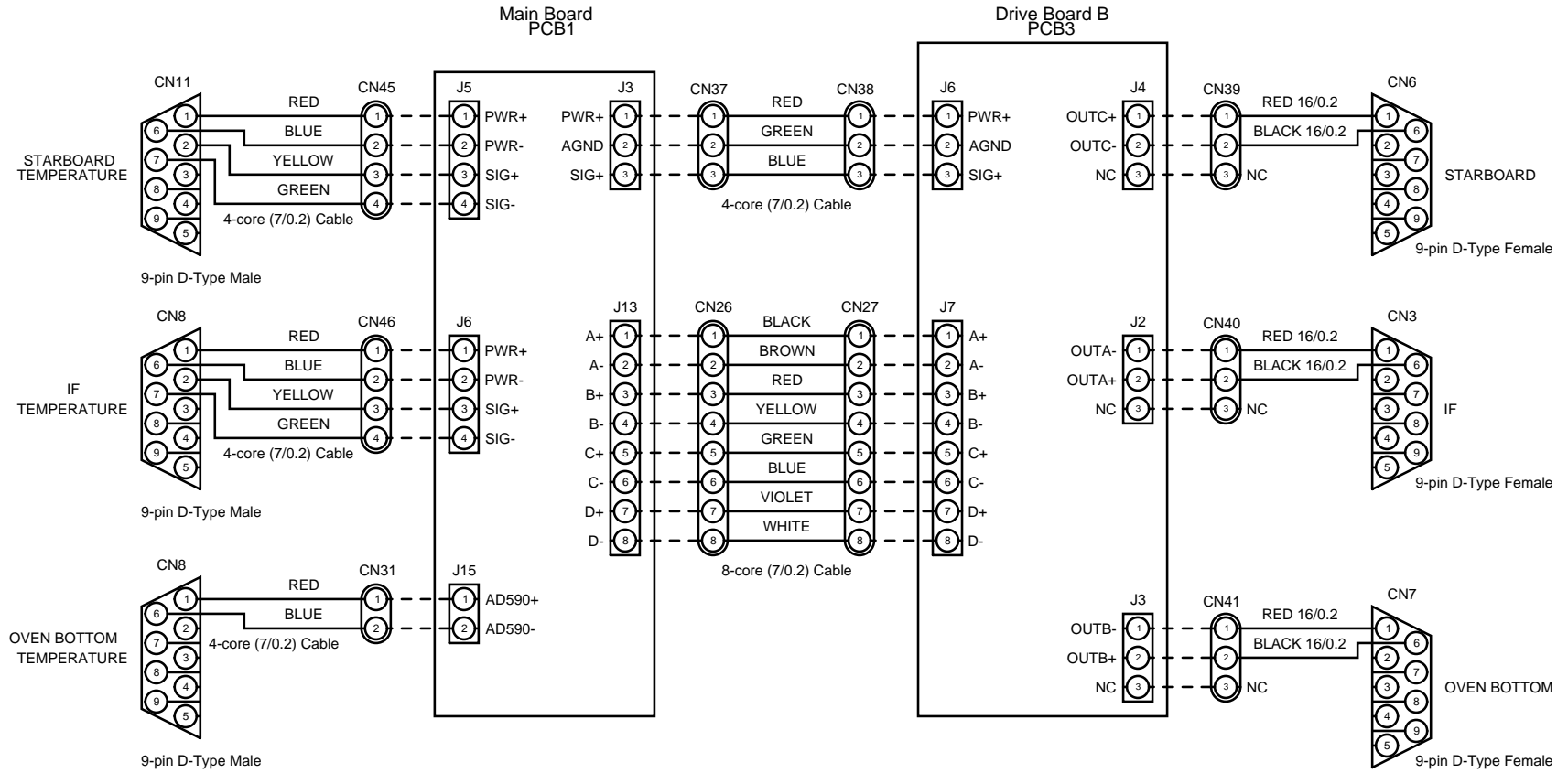

Figure 9: Spectrometer Components — Drive Board B.

4.2 Internal Wiring Parts

The parts to complete the internal wiring of the Temperature Controller have been split up into separate tables for cables and connectors.

The tables that make up the parts list for the internal wiring are summarized in Table 12.

Table 12: Internal Wiring Parts Lists

<i>Drawing</i>	<i>Figure</i>	<i>Page</i>
Cables	13	15
Connectors	14	16

Table 13: Internal Wiring Parts List — Cables

Part Number	Description (SSM)
Rapid* 01-0900	16/0.2 Wire Black 100m Reel
Rapid* 01-0935	16/0.2 Wire Red 100m Reel
Rapid* 01-0925	16/0.2 Wire Orange 100m Reel
Rapid* 01-0950	16/0.2 Wire Yellow 100m Reel
Rapid* 01-1205	32/0.2 Wire Blue 100m Reel
Rapid* 01-1215	32/0.2 Wire Green 100m Reel
Rapid* 01-1210	32/0.2 Wire Brown 100m Reel
Rapid* 02-0205	8-Core Screened Cable 100m Reel
FEC* 715-232	4-Core Screened Cable 100m Reel
Rapid* 01-0230	3-Core (16/0.2) 3A Mains Cable 100m Reel

*These items are available from Physics Stores.

Table 14: Internal Wiring Parts List — Connectors

Name	Part Number	Description (SSM)
CN1– CN3	Rapid* 33-0660	Red Insulated 6.8 × 0.8 Female Terminal pk100
CN4– CN7	Rapid* 33-0650	Red Uninsulated 4.8 × 0.8 Female Terminal pk100
CN8– CN9	Rapid 33-1274	Red 1.9 × 12mm Pin Terminal pk100
CN10– CN13	Rapid* 33-0640	Red Uninsulated 6.8 × 0.8 Female Terminal pk100
CN14	Rapid 33-0605	Red Ring Terminal 3.7mm pk100
CN15	Rapid 22-2510	4-Way 0.156” Crimp Housing
CN16– CN19	Rapid 22-2505	3-Way 0.156” Crimp Housing
CN20– CN23	Rapid 22-0920	5-Way Molex KK Crimp Housing
CN24– CN27	Rapid 22-0930	8-Way Molex KK Crimp Housing
CN28– CN29	Rapid 22-0925	6-Way Molex KK Crimp Housing
CN30– CN31	Rapid 22-0905	2-Way Molex KK Crimp Housing
CN32– CN41	Rapid 22-0910	3-Way Molex KK Crimp Housing
CN42– CN46	Rapid 22-0915	4-Way Molex KK Crimp Housing
—	Rapid 22-1098	Molex KK Crimp Terminal pk1000
—	Rapid 22-2576	0.156” Crimp Terminal pk1000

*These items are available from Physics Stores.

5 System Design

Currently in Sutherland the spectrometer (Fred) is connected to two systems, namely the Sutherland Temperature Controllers [4] and, the Sutherland Temperature Monitor [5].

Figure 10 shows all of the connections that are required for the Temperature Controller system.

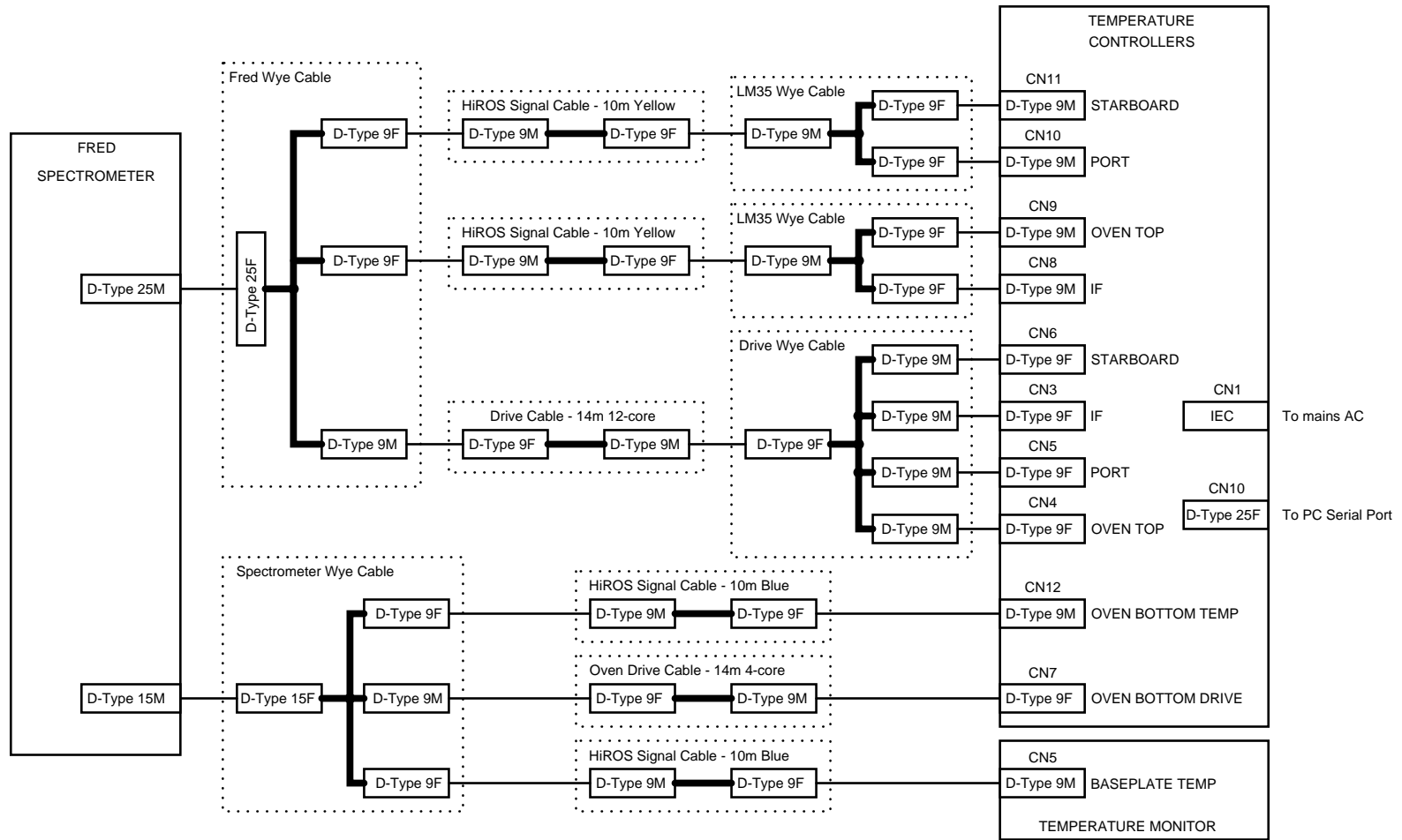

Figure 10: The Sutherland Temperature Controller System.

6 External Connections & Cable Assemblies

Figure 10 shows how all of the sensors are connected to the temperature monitor. There are basically seven different types of cable assemblies that are associated with the Sutherland Temperature Monitor, these are summarized in Table 15.

Table 15: Sutherland Temperature Controller External Cable Assemblies

<i>Drawing</i>	<i>Figure</i>	<i>Page</i>
HiROS Signal Cable	11	19
Drive Cable	12	20
Oven Bottom Drive Cable	13	20
LM35 Wye Cable	14	20
Drive Wye Cable	15	21
Fred Wye Cable	16	22
Spectrometer Wye Cable	17	23

6.1 HiROS Signal Cable

The majority of signals have to travel from a remote sensor to some instrument. Because of this it was decided to adopt a standard cable that is used on any system that requires signals to travel over a considerable distance.

The HiROS signal cable is this standard cable. It is basically a network cable that has D-Type connectors fitted on each end. The cable is made up of 4 twisted pairs of 7/0.2 wires. The cables come in a variety of different lengths and several different outer sheath colours are available including yellow, blue and red.

Figure 11 shows how the cable is connected internally.

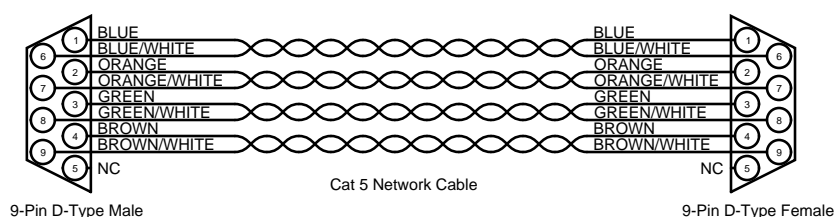

Figure 11: The HiROS Signal Cable.

6.2 Drive Cable

The drive cable is very similar to the HiROS signal cable. The only difference is the cable type and length that is used. The signals that are carried by the drive cable are power signals and so do not require twisted pair cable.

Figure 12 shows how the cable is connected internally.

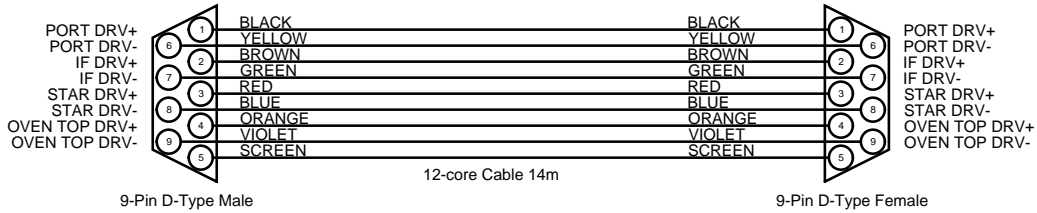

Figure 12: The Drive Cable.

6.3 Oven Bottom Drive Cable

The Oven Bottom Drive Cable is basically the same as the drive cable except that it only carries the power for the oven bottom heater.

Figure 13 shows how the cable is connected internally.

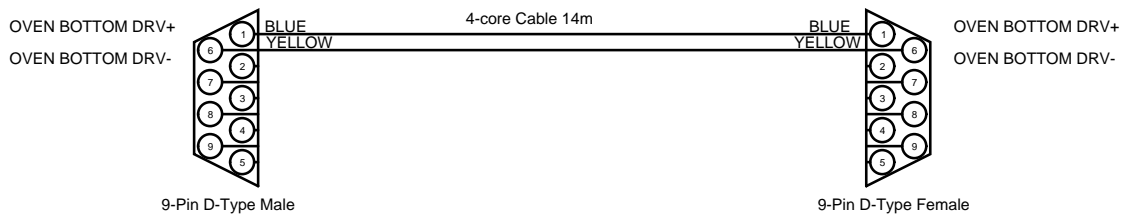

Figure 13: The Oven Bottom Drive Cable.

6.4 LM35 Wye Cable

The LM35 Wye cable is used to separate the signals from two LM35 temperature sensors that have been grouped together for transmission down a HiROS signal cable.

Figure 14 shows how the cable is connected internally.

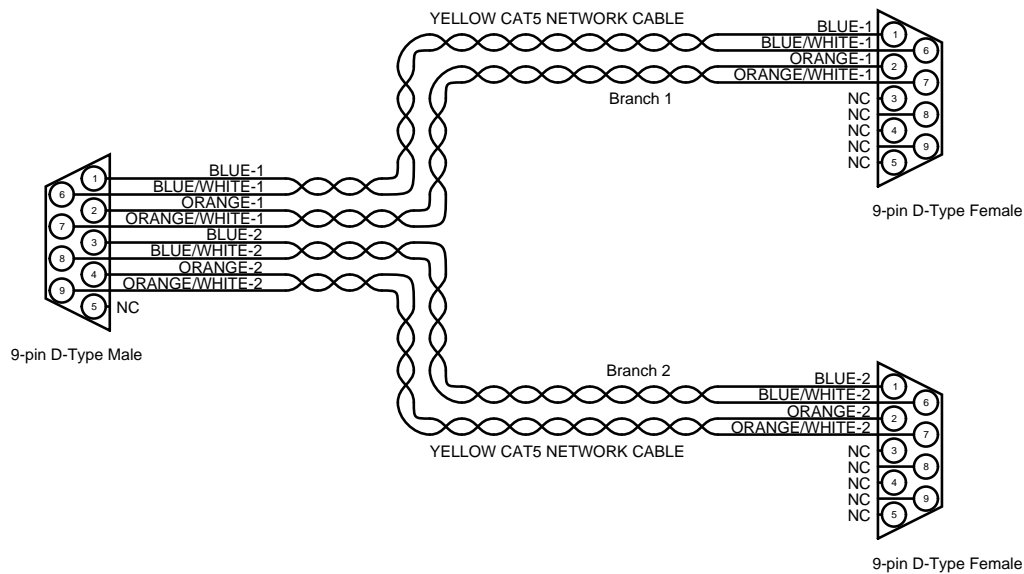

Figure 14: The LM35 Wye Cable.

6.5 Drive Wye Cable

The Drive Wye cable is used to combine the four drive signals so that they can be transmitted to the spectrometer over a single twisted pair network cable.

Figure 15 shows how the cable is connected internally.

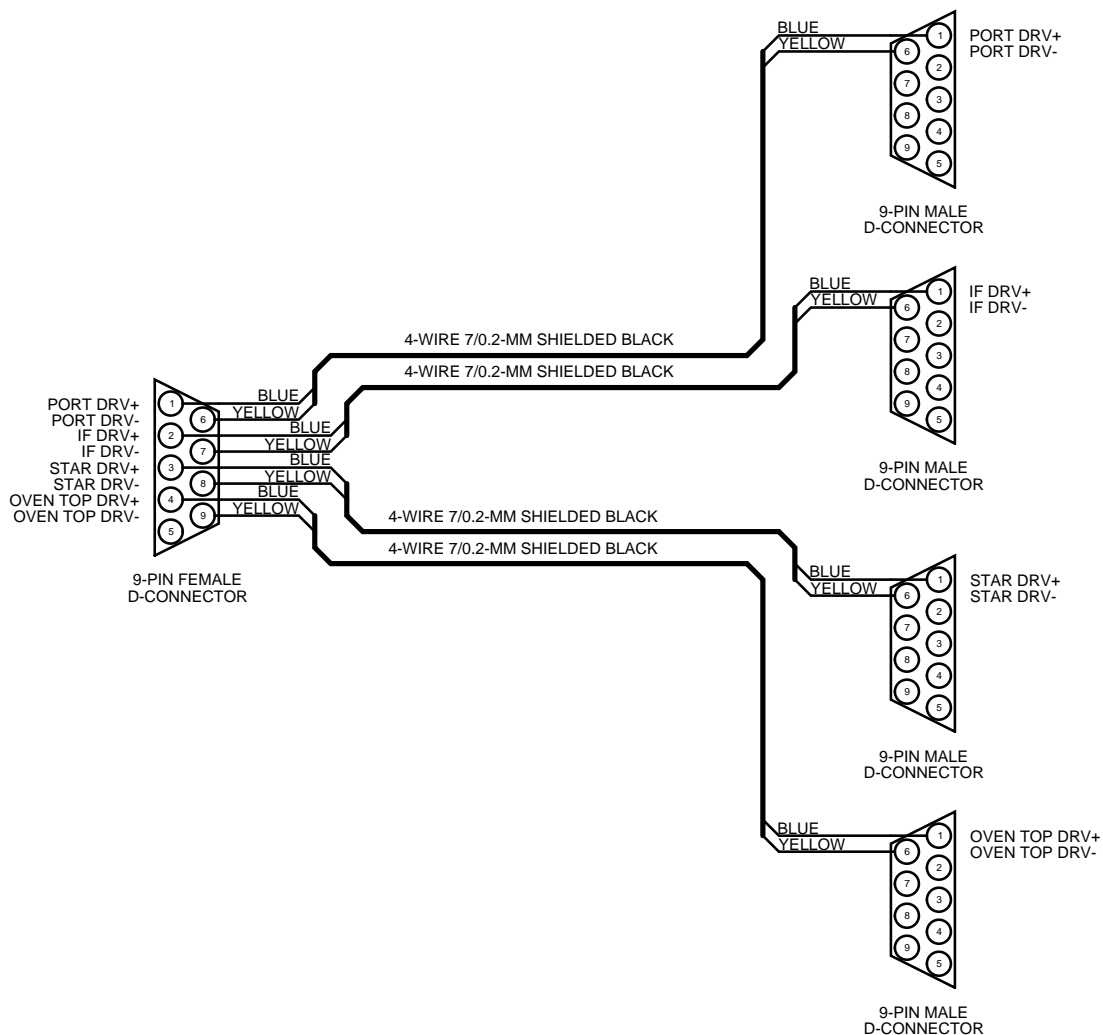

Figure 15: The Drive Wye Cable.

6.6 Fred Wye Cable

The Fred Wye Cable is used to split the many signals from the spectrometer so that they can be transmitted via HiROS signal cables.

Figure 16 shows how the cable is connected internally.

6.7 Spectrometer Wye Cable

The Spectrometer Wye Cable is used to split up the spectrometer baseplate temperature signal from the oven bottom signals as they go to two different units.

Figure 17 shows how the cable is connected internally.

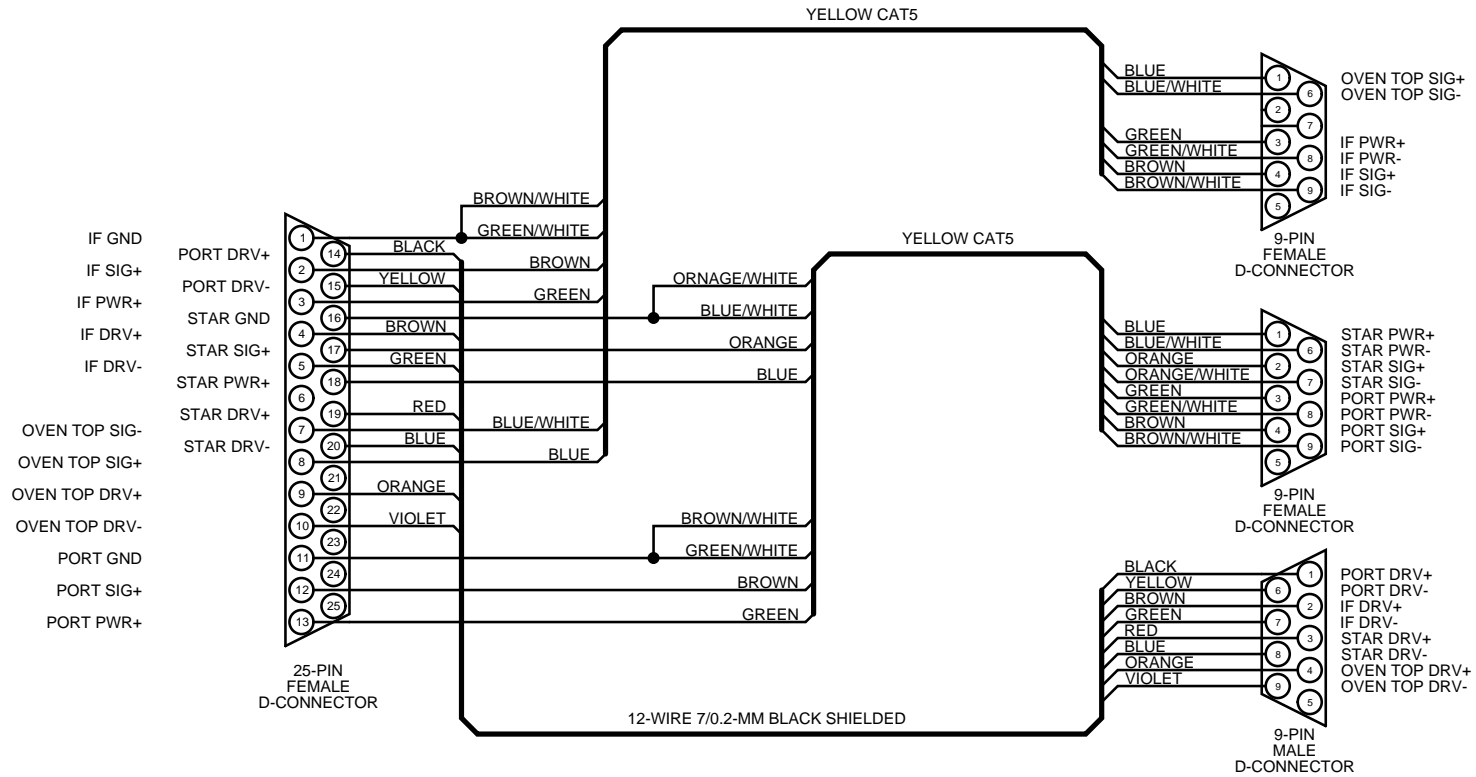

Figure 16: The Fred Wye Cable.

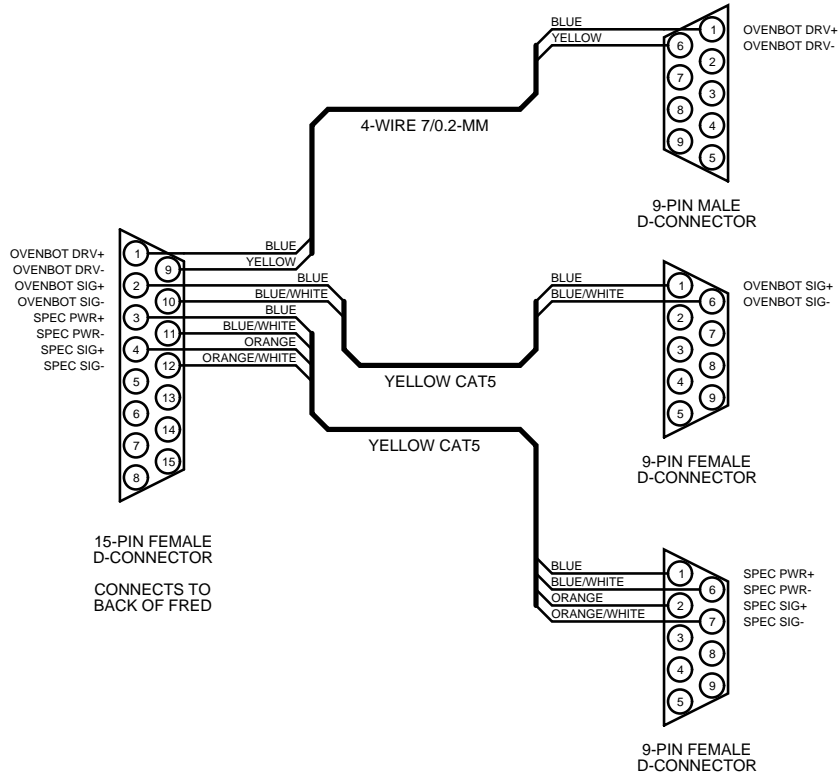

Figure 17: The Spectrometer Wye Cable.

6.8 External Cable Assembly Parts

Table 16: Parts List — External Cable Assemblies

Part Number	Description (SSM)
Rapid* 15-0535	25-pin Female D-Type Connector
Rapid* 15-0525	9-Pin Female D-Type Connector
Rapid* 15-0525	9-Pin Female D-Type Connector
Rapid* 15-0530	15-Pin Female D-Type Connector
RS 544-3402	D-Type Connector Hood 9-Pin (10)
RS 544-3430	D-Type Connector Hood 25-Pin (10)
RS 544-3418	D-Type Connector Hood 15-Pin (10)
Rapid* 19-4424	Yellow 10-meter Network Cable
FEC* 119-0267	12-Core (7/0.2) Screened Black Cable 100m Reel
FEC* 119-0255	4-Core (7/0.2) Screened Black Cable 100m Reel

*These items are available from Physics Stores.

7 Mechanical Drawings

There are two mechanical drawings that are associated with the Sutherland V/F Power Box and these are summarized in Table 17.

Table 17: Mechanical Drawings

<i>Drawing</i>	<i>Figure</i>	<i>Page</i>
Front Panel	18	25
Rear Panel	19	26

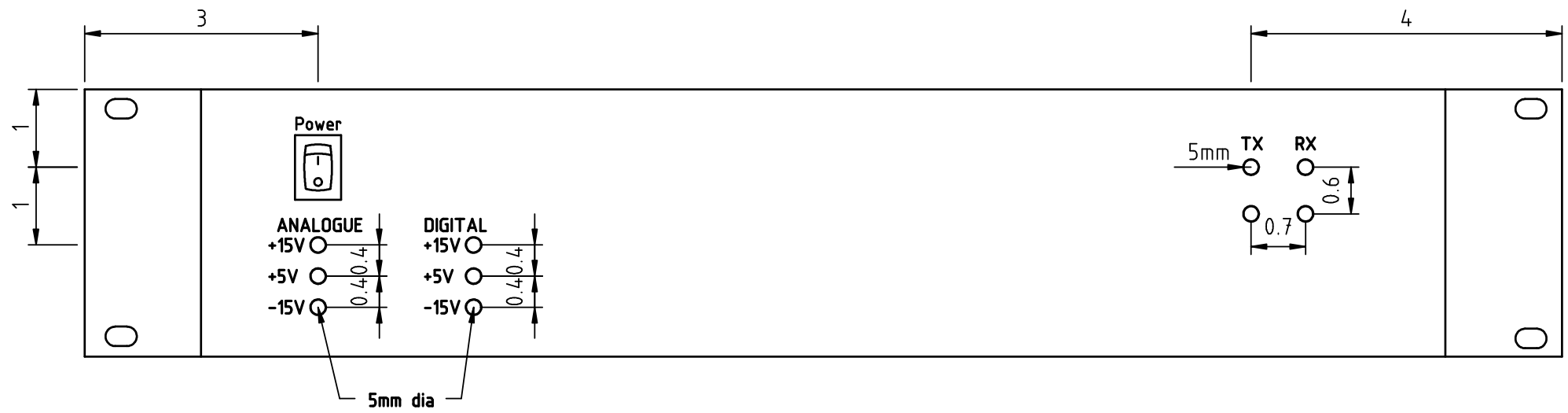

Figure 18: The Front Panel of the Sutherland Temperature Controller.

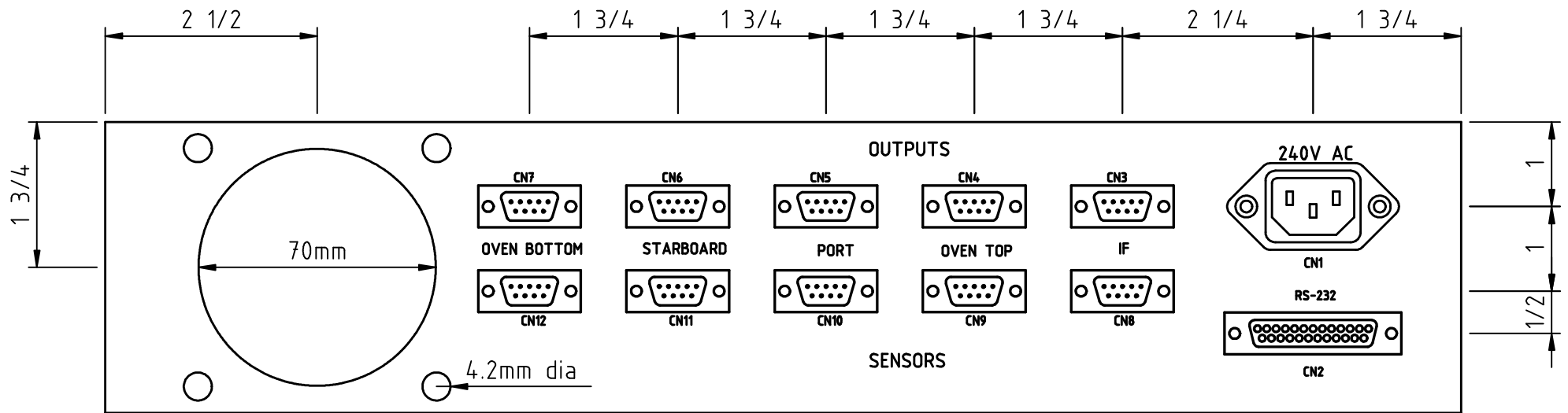

Figure 19: The Rear Panel of the Sutherland Temperature Controller.

References

- [1] IAN BARNES AND BREK MILLER. A computer-controlled temperature controller. *BISON Technical Report Series*, Number 315, High-Resolution Optical-Spectroscopy Group, Birmingham, United Kingdom, January 2009.
- [2] IAN BARNES. The installation of the Sutherland Temperature Controllers in 2007 August. *BISON Technical Report Series*, Number 294, High-Resolution Optical-Spectroscopy Group, Birmingham, United Kingdom, January 2008.
- [3] IAN BARNES AND BREK MILLER. A computer-controlled temperature controller. *BISON Technical Report Series*, Number 296, High-Resolution Optical-Spectroscopy Group, Birmingham, United Kingdom, January 2008.
- [4] BREK A. MILLER. Sutherland temperature controllers. *BISON Technical Report Series*, Number 155, High-Resolution Optical-Spectroscopy Group, Birmingham, United Kingdom, November 2000.
- [5] IAN BARNES. Temperature-monitor unit for Sutherland. *BISON Technical Report Series*, Number 277, High-Resolution Optical-Spectroscopy Group, Birmingham, United Kingdom, October 2006.